

# User Manual

## Isolated logic channel module

### 917008000

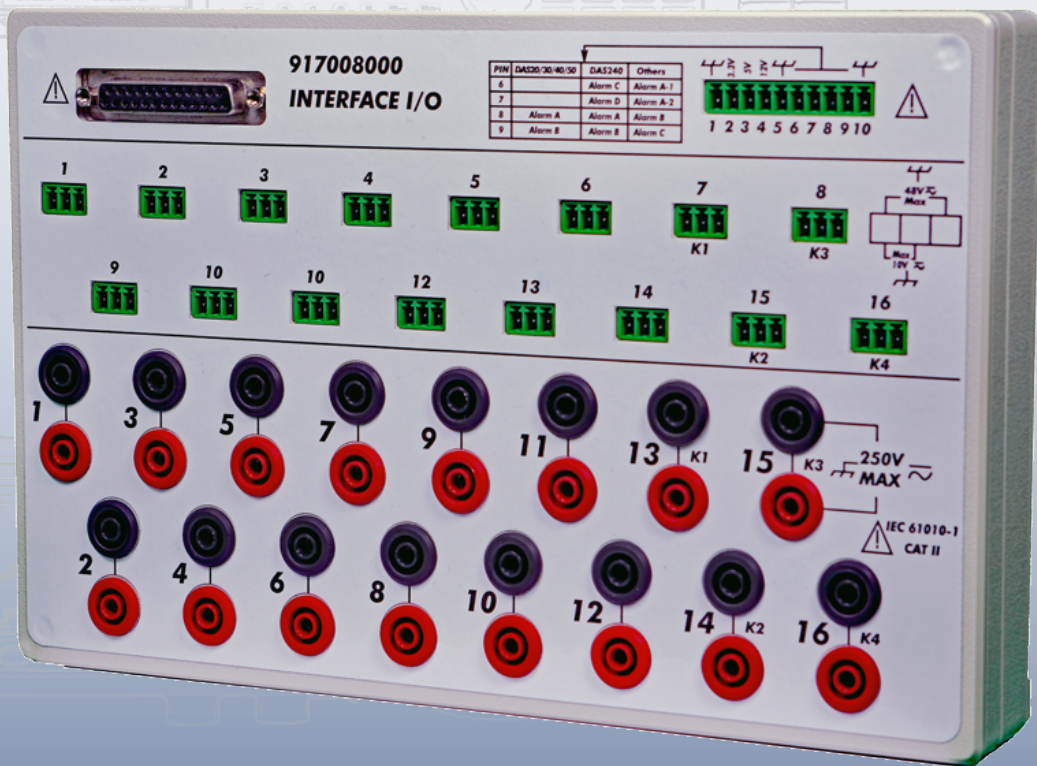

# Contents

<b>1</b>	<b>Presentation</b>	<b>3</b>
<b>2</b>	<b>Use</b>	<b>4</b>
2.1	Logic channels inputs . . . . .	4
2.2	Power supplies and alarms outputs . . . . .	4
<b>3</b>	<b>Specifications</b>	<b>6</b>
3.1	Specifications of the logic channel inputs . . . . .	6
3.2	Response time . . . . .	7
3.3	Safety, insulation class, installation category . . . . .	7
3.4	Environmental conditions . . . . .	8
<b>4</b>	<b>Conditions</b>	<b>10</b>
4.1	Warranty . . . . .	10
4.2	Metrology . . . . .	10
4.3	Packaging . . . . .	11

## Chapter 1

# Presentation

- The isolated channel module is an accessory only compatible with the SEFRAM Data Acquisition Systems: DAS220-240 / DAS30-50-60 / DAS1700-8460.
- This module allows the 16 logic channels (inputs / outputs) present on the DAS range to be deported via the Sub-D 25 connector. Equipped with optocouplers, it allows to increase the voltage input capacity of the logic channels (normally limited to 24V without this accessory), while bringing a comfort for the wiring on your equipments.
- - The applications are multiple, such as the monitoring of logical state changes in an electrical cabinet (electrical relays, contacts..).

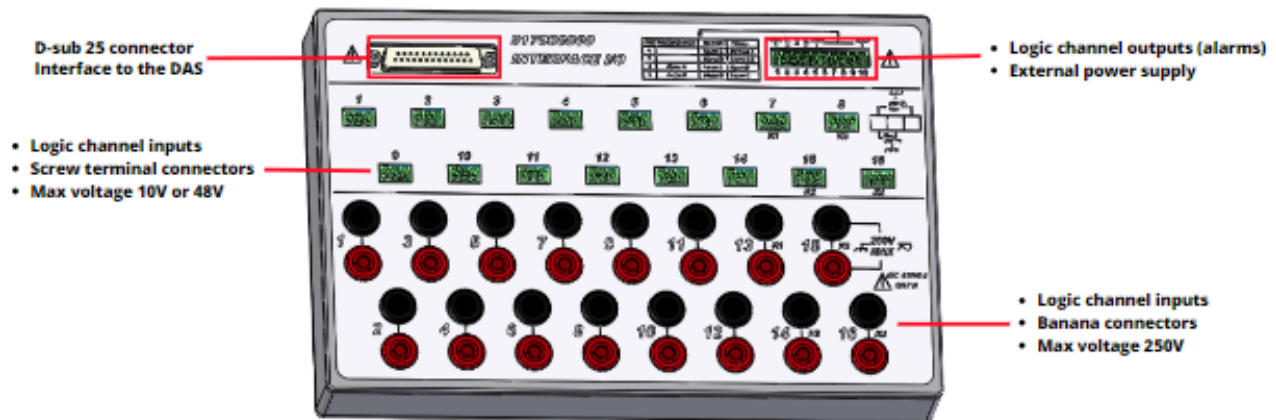
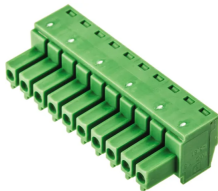

Figure 1.1: General presentation

- **Screw connector 3C (x12)** : see chapter 2.1 for use



- **Screw connector 3C (x12)** : see chapter 2.2 for use



These accessories can be provided as spare parts with the kit 984405600

## Chapter 2

# Use

## 2.1 | Logic channels inputs

First of all you have to connect the D-sub 25 wires cable between the isolated channel module and the DAS (4). Then choose the input on which to connect your signal according to the voltage allowed:

- **90V to 250V** DC or AC between red and black socket (1)
- **10V to 48V** DC or AC between pins 1 and 3 of the green terminal block (2)
- **Below 10V** DC or AC between pin 1 and 2 of the green terminal block (3)

All inputs are isolated from each other and from ground.

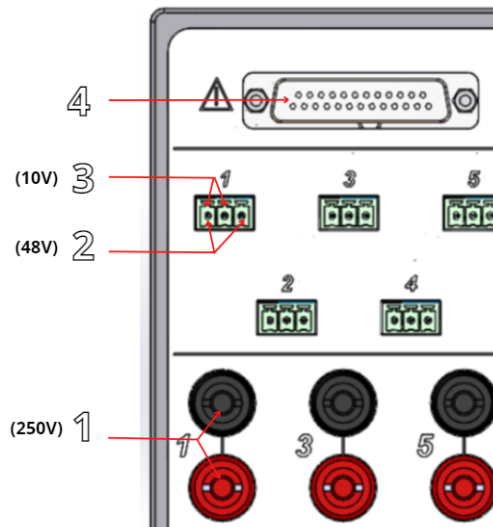

Figure 2.1: Maximal voltage input allowed

## 2.2 | Power supplies and alarms outputs

The 10-contact terminal block is not isolated. The grounds are connected together. It allows 3,3V, 5V or 12V voltage supplies of an external circuit (sensor or other) or to output the TTL 0-5V signals (alarms) of the Data Acquisition System. The maximum current output is 200 mA.

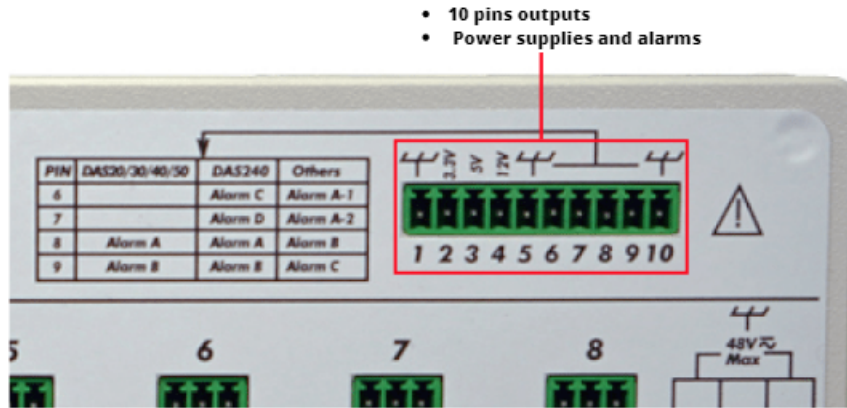

Figure 2.2: Power supplies and alarms outputs

The different pins are arranged as follows:

Pin number	Type	Signal	Devices
1	Ground	-	DAS220/240 ; DAS30/50/60 ; DAS1700/8460
5		-	DAS220/240 ; DAS30/50/60 ; DAS1700/8460
10		-	DAS220/240 ; DAS30/50/60 ; DAS1700/8460
2	Supply	3.3V	DAS220/240 ; DAS30/50/60 ; DAS1700/8460
3	Supply	5V	DAS220/240 ; DAS30/50/60 ; DAS1700/8460
4	Supply	12V	DAS220/240 ; DAS30/50/60 ; DAS1700/8460
6	Alarm A	Dry contact terminal 1	DAS1700/8460
	Alarm C	TTL 5V	DAS220/240 ; DAS60
7	Alarm A	Dry contact terminal 2	DAS1700/8460
	Alarm D	TTL 5V	DAS220/240 ; DAS60
8	Alarm B	TTL 5V	DAS1700/8460
	Alarm A		DAS220/240 ; DAS30/50/60
9	Alarm C	TTL 5V	DAS1700/8460
	Alarm B		DAS220/240 ; DAS30/50/60

Figure 2.3: Description of the power supplies and alarms pins

**Chapter 3**

# Specifications

## 3.1 | Specifications of the logic channel inputs

**Caution: Only use accessories with a security category at least equal to the input card.**

### From 0 to 250V:

- Isolated banana plug between red and black socket
- Maximal voltage allowed: 250V DC or AC
- Typical switching threshold (AC or DC): 48V
- Frequency: 45 to 440Hz
- Low threshold not detected (AC or DC): 0 to 10V
- High threshold detected (AC or DC): 60V to 250V
- Isolation: 250V= $\sim$  between channel and ground



### From 0 to 48V:

- By screw terminal between pin 1 and 3 of the terminal block
- Maximal voltage allowed: 48V DC or AC
- Frequency: 45 to 440Hz
- Typical switching threshold (AC or DC): 9V
- Low threshold not detected (AC or DC): 0 to 2V
- High threshold detected (AC or DC): 10 to 48V
- Isolation: 50V= $\sim$  entre channel and ground

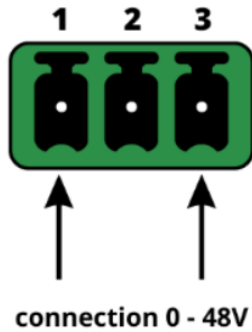

### From 0 to 10V :

- By screw terminal between pin 1 and 2 of the terminal block
- Maximal voltage allowed: 10V DC or AC
- Frequency: 45 to 440Hz
- Typical switching threshold (AC or DC): 2,2V
- Low threshold not detected (AC or DC): 0 to 1V
- High threshold detected (AC or DC): 3 to 10V
- Isolation: 50V= $\sim$  between channel and ground

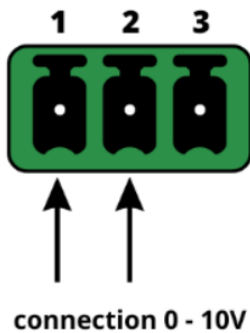

## 3.2 | Response time

To detect AC, the signal of the logic channels is rectified and filtered.

- Typical delay for a rising signal: 10ms
- Typical delay for a descending signal: 50ms

## 3.3 | Safety, insulation class, installation category

- Complies with standard EN61010-1 and EN61010-2-030
- Pollution degree: 2

- Safety: CAT II 250V

**Caution: special precautions must be taken to maintain product compliance, including the use of cords corresponding to the measurement input category.**

## 3.4 | Environmental conditions

### Climate conditions

- Operating temperature: 0 to 40 °C
- Maximum relative humidity: 80 % non-condensing
- Storage temperature: -20 to 60 °C
- Maximum altitude: 2000m



## Power supply

- Power is supplied by the recorder via the 25-pin SUB-D connector.
- **Caution: use only the supplied cable and a SEFRAM device from the data acquisition range. Refer to the device's manual**

## Dimensions and weight

- Height: 160mm
- Width: 250mm
- Depth: 37mm
- Masse: 620g

## Chapter 4

# Conditions

## 4.1 | Warranty

Your instrument is warranted for two years against defects in materials and workmanship. This warranty applies from the date of delivery and ends 730 calendar days later. If the unit is covered by a warranty agreement, the warranty agreement supplements, supersedes, or replaces the warranty terms listed above. The warranty conditions applicable by SEFRAM are available on the website [www.sefram.com](http://www.sefram.com)

The terms and conditions of this warranty take precedence over this summary. This warranty does not cover defects resulting from abnormal use, handling errors or storage conditions outside the defined range. In the event of a warranty claim, the user must return the device concerned to our factory at his own expense :

**SEFRAM Instruments SAS Service Après-vente 32,**

**Rue Edouard MARTEL BP 55 42009 SAINT-ETIENNE CEDEX 2**

and write a description of the fault found with the equipment. The accessories delivered as standard with the device (cords, plugs...) are guaranteed for 3 months against manufacturing defects. Wear and tear, accidental breakage or breakage resulting from a shock or abnormal use are not guaranteed. The time remaining to be covered if the device is guaranteed - If the warranty of the device < 90 days, the replaced part is guaranteed 90 days

Any replacement part becomes the property of the user and the exchanged parts become the property of SEFRAM. In case of insurance coverage, the product becomes the property of the latter at its exclusive request. Otherwise it remains the property of the user. The warranty applies only to equipment manufactured and supplied by SEFRAM. Any intervention or modification made by the user or by a third party without prior authorization from the company will result in the loss of the benefit of the warranty. The user is responsible for the return of the equipment to our premises. He must therefore ensure that the packaging will allow proper protection during transport. He must take out the necessary insurance for the transport at his own expense. SEFRAM reserves the right to refuse a poorly packed product, and not to propose a repair if the breakage is due to transport.

### **What to do in case of dysfunction:**

In case of dysfunctions or operating problems, please contact SEFRAM Instruments & Systems technical support. A technician will take your call and give you all the necessary information to solve your problem.

### **Advice or technical assistance:**

SEFRAM Instruments & Systems is committed to helping you by phone to use your device by calling 04 77 59 01 01 or by email at [support@sefram.com](mailto:support@sefram.com)

### **What to do in case of a breakdown?**

Please return your equipment with the RMA document previously registered on our website to:

[www.sefram.com/services.html](http://www.sefram.com/services.html) then click on Return Material Authorization (RMA).

For any further information you can contact the after-sales service by phone at 04 77 59 01 01 or by mail at [services@sefram.com](mailto:services@sefram.com)

## 4.2 | Metrology

You are in possession of a measuring instrument for which the metrological conditions are defined in the specifications of this manual. The climatic and environmental conditions limit the specifications of your Instrument. SEFRAM checks the characteristics of each instrument individually on an automatic rack during its manufacture. Adjustment and verification are guaranteed within the framework of ISO9001 certification by measuring instruments connected to COFRAC (or equivalent in ILAC reciprocity). When a product returns to SEFRAM, a maximum service is ensured with internal upgrading according to the necessary evolutions and software upgrading. In case of deviation from the specifications, your instrument will be adjusted to its original characteristics.

## 4.3 | Packaging

The packaging of this product is entirely recyclable. It is designed to transport your instrument in the best conditions. We draw your attention to the fact that the original packaging must be over-packed if it is used for transport by air, road or mail. We recommend that you keep the original packaging for any transport.